

# Installation and Operation Manual

## SunTouch® ConnectPlus™ Smart Sensor

### Description

The ConnectPlus™ Smart Sensor is a temperature and water leakage sensor that pairs to the ConnectPlus thermostat. This device can be used as an optional floor temperature sensor for the radiant floor heating system. Detected water leaks produce audible and visual alarms, and notifications are transmitted to the thermostat.

### Where to Use

#### Temperature Sensor

Place the Smart Sensor directly on a heated section of the floor to use as a floor control sensor.

#### Water Leakage Sensor

Place the Smart Sensor directly on the floor where there is a risk of water leakage (near water lines, washing machines, hot water tanks, ...) within range of the ConnectPlus thermostat.

### Specifications

- Power: 2 x AA batteries included
- Battery Life : 1 year
- Range: 75 ft, line-of-sight
- Pairing limit: 6 devices
- Operating Temperature range : 32°F to 104°F (0°C to 40°C)
- Operating Humidity range : 0 to 100% humidity
- Storage temperature range : -4°F to 122°F (-20°C to 50°C)
- IP Waterproof Class : IP67
- Diameter 3<sup>3</sup>/<sub>8</sub>" (85mm), Height 1<sup>1</sup>/<sub>16</sub>" (43mm)



#### ⚠ WARNING



**Please read carefully before proceeding with installation. Your failure to follow any attached instructions or operating parameters may lead to the product's failure. Keep this Manual for future reference.**



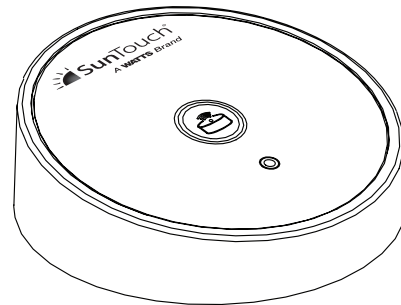

## Setup

Wireless Pairing:

- Put the ConnectPlus into pairing mode:  
Menu > Settings > Paired Devices > Pair Device
- Press and hold button on the Smart Sensor for 3 seconds

Wake: short button press

Status Indicators:

Not paired	Orange blink
Pairing	Orange blink
Paired	Green steady
Water Leak	Red/Green blink & buzzer
Error	Red steady
Low Battery	Red blink

Pairing Mode: hold the button down for 3 sec (30 sec timeout)

Silence Buzzer: short button press

Power  
2 X AA Batteries

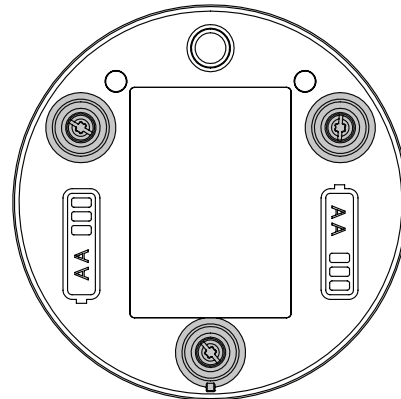
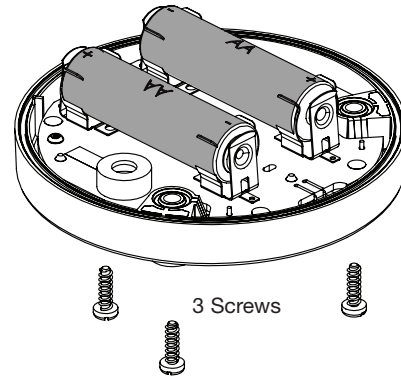

Sensors are located  
on the bottom

### Limited 3 Year Warranty

SunTouch warrants this control (the product) to be free from defect in material and workmanship for a period of (3) years from the date of original purchase from authorized dealers. During this period, SunTouch will replace the product or refund the original cost of the product at SunTouch's option, without charge, if the product is proven defective in normal use. Please return the control to your distributor to begin the warranty process.

This limited warranty does not cover shipping costs. Nor does it cover a product subjected to misuse or accidental damage. This warranty does not cover the cost of installation, diagnosis, removal or reinstallation, or any material costs or loss of use.

This limited warranty is in lieu of all other warranties, obligations, or liabilities expressed or implied by the company. In no event shall SunTouch be liable for consequential or incidental damages resulting from installation of this product. Some states or provinces do not allow limitations on how long an implied warranty lasts, or the exclusion or limitation of incidental or consequential damages, so the above exclusions or limitations may not apply to you. This warranty gives you specific legal rights and you may also have other rights that vary from state to state.



A WATTS Brand

USA: T: (888) 432-8932 • F: (417) 831-4067 • SunTouch.com

Canada: T: (888) 208-8927 • F: (905) 481-2316

Latin America: T: (52) 55-4122-0138 • SunTouch.com

## Engineering Specification

Job Name \_\_\_\_\_  
 Job Location \_\_\_\_\_  
 Engineer \_\_\_\_\_  
 Approval \_\_\_\_\_

Contractor \_\_\_\_\_  
 Approval \_\_\_\_\_  
 Contractor's P.O. No. \_\_\_\_\_  
 Representative \_\_\_\_\_

# ConnectPlus™ Smart Sensor

The ConnectPlus™ Smart Sensor is a temperature and water leakage sensor that pairs to the ConnectPlus thermostat. This device can be used as an optional floor temperature sensor for the radiant floor heating system. Detected water leaks produce audible and visual alarms, and notifications are transmitted to the thermostat.

### Specifications

<b>Literature</b>	IOM-ST-CPSS, ES-ST-CPSS
<b>Power</b>	2 x AA Batteries Included
<b>Battery Life</b>	1 Year
<b>Operating Temperature</b>	32°F to 104°F (0°C to 40°C)
<b>Operating Humidity Range</b>	0 to 100% humidity
<b>Storage Range</b>	-4°F to 122°F (-20°C to 50°C)
<b>IP Waterproof Case</b>	IP67
<b>Dimensions</b>	Diameter 3 3/8" (85.38mm), Height 1 1/16" (42.87mm)

### NOTICE

The ConnectPlus Smart Sensor is only compatible with the SunStat® ConnectPlus model. Does not connect to older model SunStat thermostats.

### Status Indicators:

Not paired	Orange blink
Pairing	Green blink
Paired	Green steady
Water Leak	Red/Green blink & buzzer
Error	Red steady
Low Battery	Red blink

FCC ID: 2AFJT - CIMDOF18815  
 IC: 20938 - CIMDOF18815

### CAUTION

This Engineering Sheet is not intended to provide full installation instructions and safety information. In order to avoid property damage or injury, please refer to the complete installation manual and product safety information provided with the product.



ConnectPlus Smart Sensor

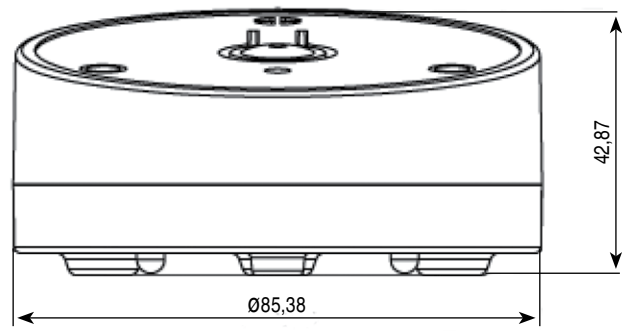

### PRODUCT OPTIONS

Qty	Description	Model#	Order#
	ConnectPlus Smart Sensor	500120	81020611

SunTouch product specifications in U.S. customary units and metric are approximate and are provided for reference only. For precise measurements, please contact SunTouch Technical Service. SunTouch reserves the right to change or modify product design, construction, specifications, or materials without prior notice and without incurring any obligation to make such changes and modifications on SunTouch products previously or subsequently sold. Refer to the owner's manual for warranty information.



**USA:** T: (888) 432-8932 • F: (417) 831-4067 • SunTouch.com  
**Canada:** T: (888) 208-8927 • F: (905) 481-2316  
**Latin America:** T: (52) 55-4122-0138 • SunTouch.com